

Actuator

ALD12

ALD12 is a compact in-line actuator, which is easy to be applied in limited space. The in-line design provides an advantage to appearance that makes it part of the overall mechanical system without looking odd. In addition to high IP protection level, all stainless steel for better corrosion protection, which can be used for such as marine, food engineering, or other industrial automation.



Features

- Main application: Industrial
- Input voltage: 24V DC / 12V DC
- Max. load: 1500N (push / pull)
- Max. static load: 1800N
- Typical speed at no load: 17.4 mm/sec
- Typical speed at full load: 5 mm/sec (1500N load)
- Stroke: 50 / 100 / 150 / 200 / 250 / 300 / 350 / 400 mm
- IP Protection level: IP66, IP69K
- Material: All stainless steel "SUS304"
- Duty cycle: 10%, max. 2 min. continuous operation in 20 min.
- Ambient operation temperature: -20°C ~ +70°C
- Certified: CE Marking, EMC Directive 2014/30/EU

Options

- Positioning signal feedback with Hall effect sensor x 2
- Mounting bracket (MB22)
- Control box
- Power limit control - Adjustable

Performance Data

Model No.	Gear ratio	Push / Pull load Max. (N)	**Typical speed (mm/s)		**Typical current (A)			
			No load	Full load	No load		Full load	
					12V	24V	12V	24V
ALD12-XX19-M2-XXX.XXX-XXXXXXX	19:1	600	17.4	11.7	0.5	0.25	3.6	1.8
ALD12-XX27-M2-XXX.XXX-XXXXXXX	27:1	1000	12.3	8.0	0.5	0.25	3.6	1.8
ALD12-XX43-M2-XXX.XXX-XXXXXXX	43:1	1500	7.5	5.0	0.5	0.25	3.6	1.8
*ALD12-2457-K2-XXX.XXX-XXXXXXX	57:1	1500	3.5	2.3	N/A	0.2	N/A	0.8

Motor type M2

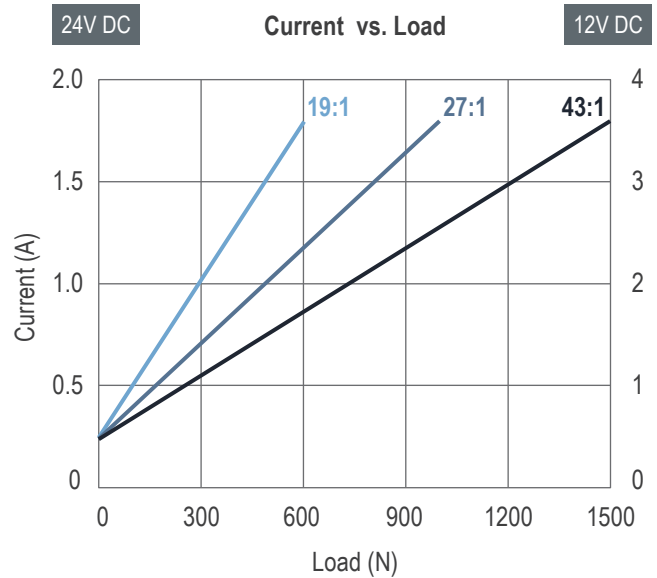
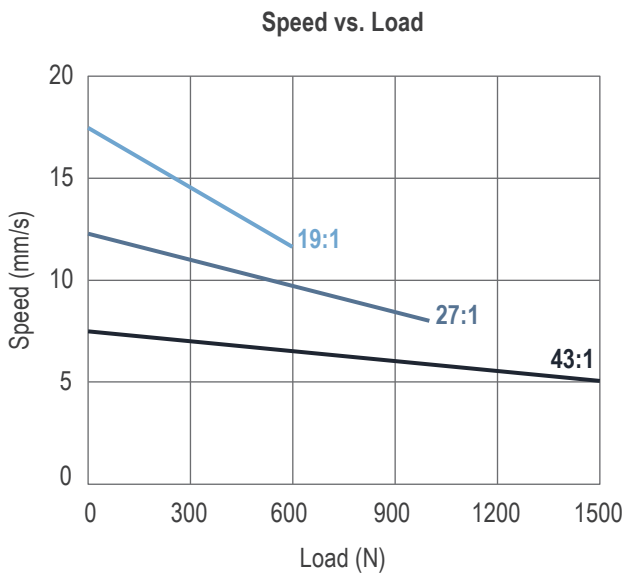

Motor type K2

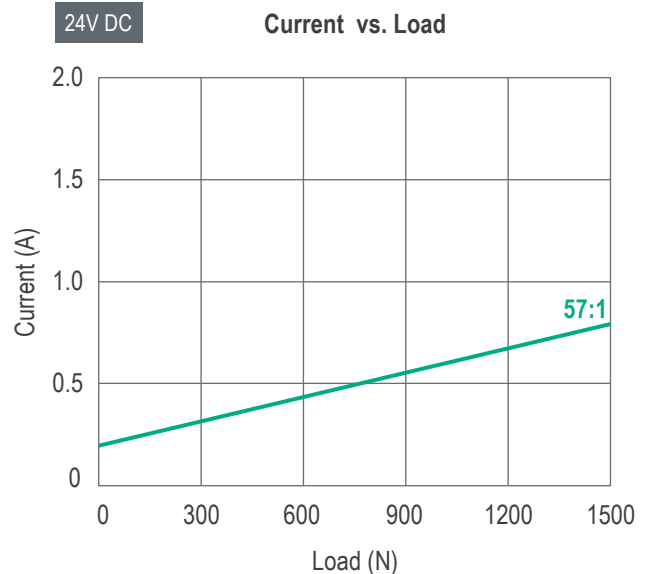
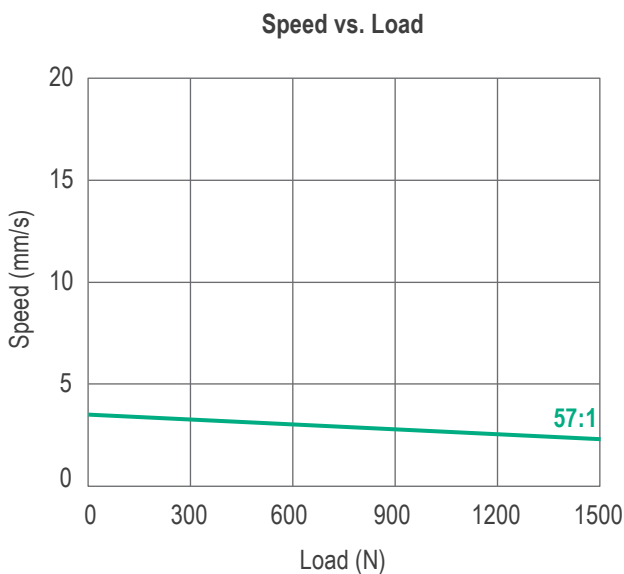

Remarks:

- * 2457-K2 is designed for applications requiring lower noise but less speed concern. 24VDC available only.
- ** The typical speed or typical current means the average value neither upper limit nor lower limit. The performance curves are made with typical values.

Dimensions

Unit: mm

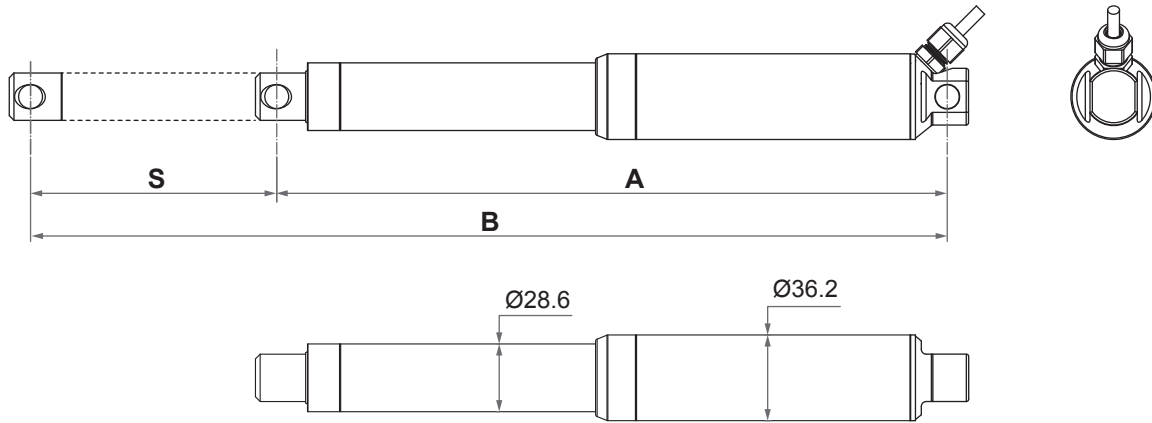

• Front connector

1=Stainless steel solid

2=Stainless steel slot

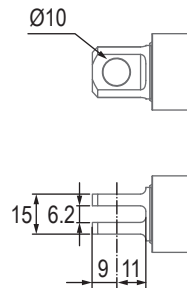
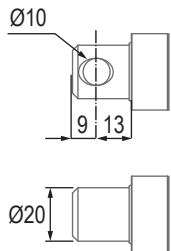

• Rear connector

1=Stainless steel solid

2=Stainless steel slot

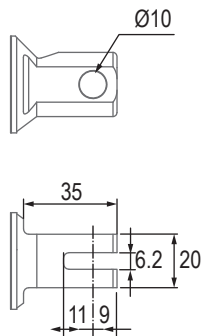
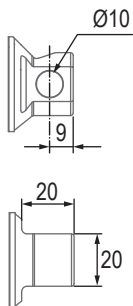

• Installation dimension

Retracted length (A)

Front connector code	Rear connector code	Stroke (S)							
		50	100	150	200	250	300	350	400
1	1	233	283	333	383	433	483	533	583
1	2	248	298	348	398	448	498	548	598
2	1	237	287	337	387	437	487	537	587
2	2	252	302	352	402	452	502	552	602

(tolerance: ±3mm)

• **Mounting bracket (MB22)**

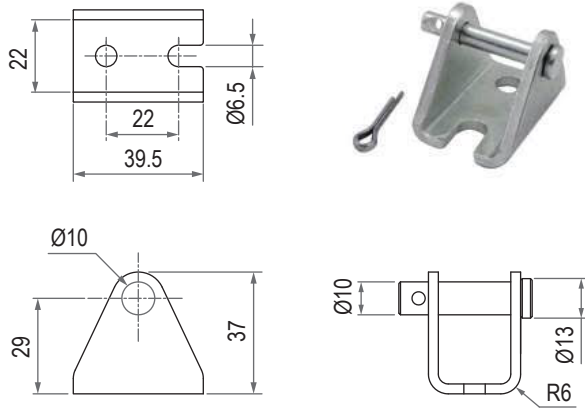

Wiring

Wire definitions:

• **Without positioning sensor feedback**

Power	
Red	Black
M+	M-

Note:

1. Connect Red (M+) to '+' & Black (M-) to '-' of DC power, the actuator will extend.

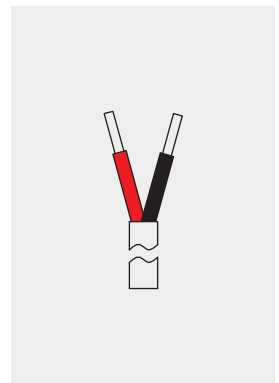

• **With Hall effect sensor x 2**

Power		Signal			
Red	Black	White	Yellow	Blue	Green
M+	M-	GND	VCC	DATA1	DATA2

Note:

1. Connect Red (M+) to '+' & Black (M-) to '-' of DC power, the actuator will extend.
2. Hall effect sensor resolution

Gear ratio	Resolution (pulses/mm)
19:1	9.56
27:1	13.50
43:1	21.45
57.1	28.43

3. Voltage input range (VCC): 3.5~20V
4. Output voltage of signal (Data) = Input voltage of VCC
5. Hall signal data

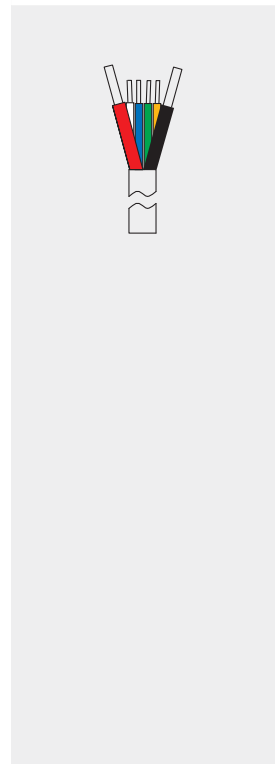
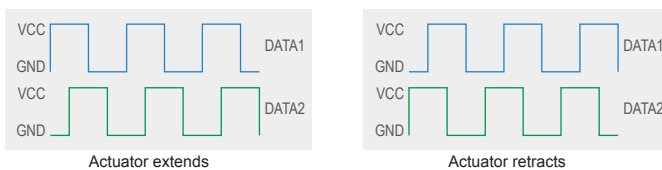

Ordering Key

ALD12 - 24 43 - M2 - 183 - 283 - S 1 1 9 H 0 1

Input voltage	12: 12V DC 24: 24V DC
Gear ratio	19: 19:1 (600N) 27: 27:1 (1000N) 43: 43:1 (1500N) 57: 57:1 (1500N, for 2457-K2 only)
Motor and spindle type	M2 K2 (Refer to Page 2)
Retracted length	XXX (Refer to Page 3)
Extended length	XXX (Refer to Page 3)
Exterior	S: All stainless steel "SUS304"
Front connector	1: Stainless steel solid 2: Stainless steel slot
Rear connector	1: Stainless steel solid 2: Stainless steel slot
IP Protection level	6: IP66 9: IP66/IP69K (for All stainless steel "SUS304")
Positioning feedback	0: None H: Hall effect sensor x 2
Mounting bracket (MB22)	0: None 1: Mounting bracket x 1 2: Mounting bracket x 2 (Refer to Page 4)
Cable length	1: 1000mm straight 2: 1500mm straight

Compatibility

Product	Model	ALD12 spec
Control box	CIS1	- 2 Actuator synchronisation - 24V motor - With single Hall effect sensor for positioning
	CIS2	- 2 Actuator synchronisation - 12V motor - With single Hall effect sensor for positioning
Power limit control - adjustable	GS24-5MO	24 Vdc motor < 5 ampere
	GS12-10MO	12 Vdc motor < 10 ampere
	GS12-5MO	12 Vdc motor < 5 ampere

Attentions

ALD12 is without built-in mechanical limit switches, and is suggested to be used with Hall sensor feedback included. Also it is strongly suggested that the customer provides a over-current protection device in the power circuit with a value setting around 1.5 times the typical full load current (page 6, GS12 & GS24). It's important that ALD12 work with a control system that prevents the actuators from constantly hitting its internal end positions, which will reduce the actuator lifespan.

Certifications

The ALD12 actuator is compliant with the following regulations, in terms of the essential conformity requirements of EMC Directive of 2014/30/EU.

Emission	Immunity
EN 61000-6-3:2007+A1:2011	EN 61000-6-1:2007 IEC 61000-4-2:2008 IEC 61000-4-3:2006+A1:2007+A2:2010 IEC 61000-4-8:2009

Tel: +31(0)30 6081717
Mail: verkoop@aamotionandcontrol.nl
www.aamotionandcontrol.nl



Terms of Use

The user is responsible for application suitability of A&A Motion and Control products. As ongoing improvement process continues, products listed on the A&A Motion and Control website are subject to change without prior notice. A&A Motion and Control reserves the right to terminate the sales or remove any product displayed on the website, or listed in its catalogues.